

bgme®

VOLTAGE REGULATOR

BGM VOLTAGE REGULATOR – 4-plug AC/DC

Thank you for purchasing our bgm Pro regulator. For full customer support, please find included these fitting instructions. To show the basic principle we have chosen some common electrical setups and included the wiring diagrams.

APPLICATIONS

The bgm Pro regulator is the most versatile and powerful on the market. Thanks to AC and DC output it can be used for all Lambretta and Vespa scooters equipped with 12 V electronic ignitions. Additionally it can be used as a high quality replacement for most common Twist & Go scooters. To ease up your life in the workshop the connections of the regulator are shown at the back.

FEATURES

AC-AC (alternating current): IN for the current delivery of the stator plate and OUT for the regulated AC current for the wiring loom.

Sense: To use the regulator the AC IN and OUT has to be bridged. The special wiring loom is included in the delivery of every bgm Pro regulator. This so-called SENSE function checks the power OUT against a reference value and keeps it stable. So the power output is constant even with alternating load.

DC (direct current): OUT with DC for charging the battery. With ignition systems capable of high power output, consumers can be fed directly without a battery used (e.g. Satnav systems, water pumps, rev counters, speedos and all sort of other toys).

Earth: Can be taken easily from the old existing regulator. If there wasn't an earth connection, you should install one. Use the earth out of the regulator and connect it to the frame of the scooter. Make sure this is fitted to a bare metal part of the frame. Ideally you should additionally wire the earth to the body of the regulator as well.

On the next pages you'll find wiring diagrams for the most common setups. These examples show the basic principle and can be helpful to see how to connect it to any other scooter.

Lambretta

- To our own bgm PRO wiring looms
- MB Developments loom
- Casa Lambretta loom
- Original type AC loom with 12 V electronic ignition
- Original type DC loom with 12 V electronic ignition
- Varitronic/Casa Lambretta

Vespa

- Vespatronic/Parmakit
- Vespa 3-Pin regulator
- Vespa 5-Pin regulator

For questions or general technical support contact info@bgm-tuning.com

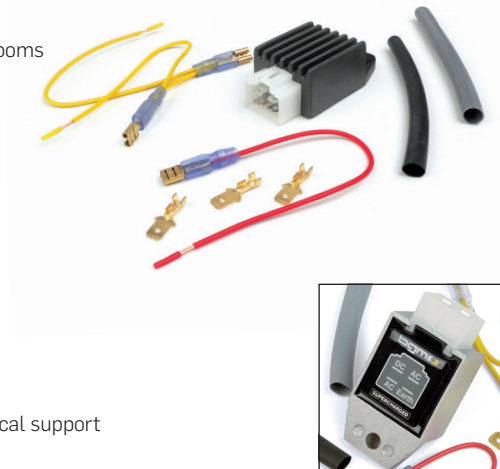

LAMBRETTA
MB DEVELOPMENTS LOOM

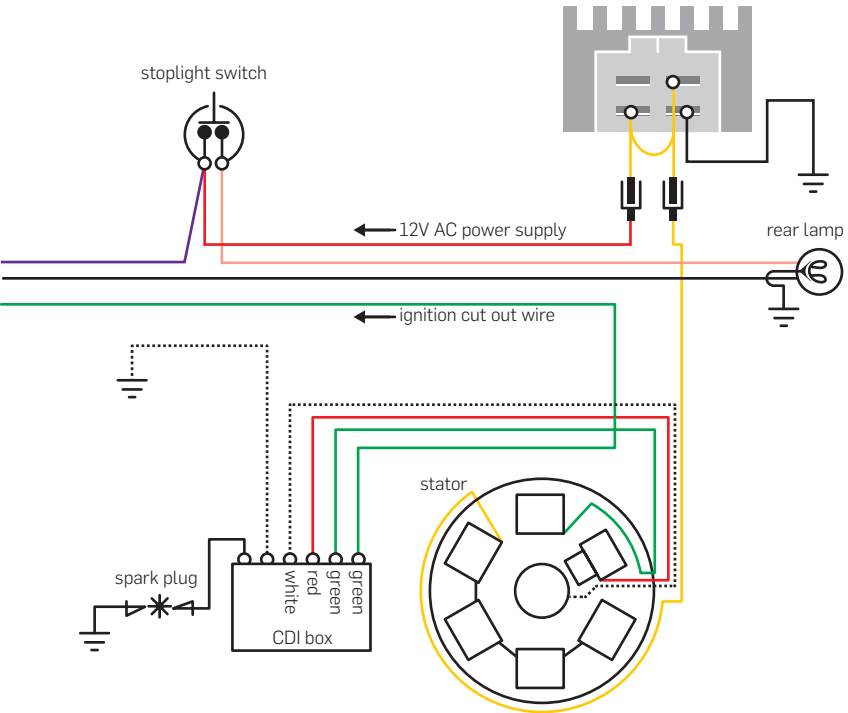

for reference: Sticky page 280

LAMBRETTA
CASA LAMBRETTA LOOM + BGM PRO LOOM

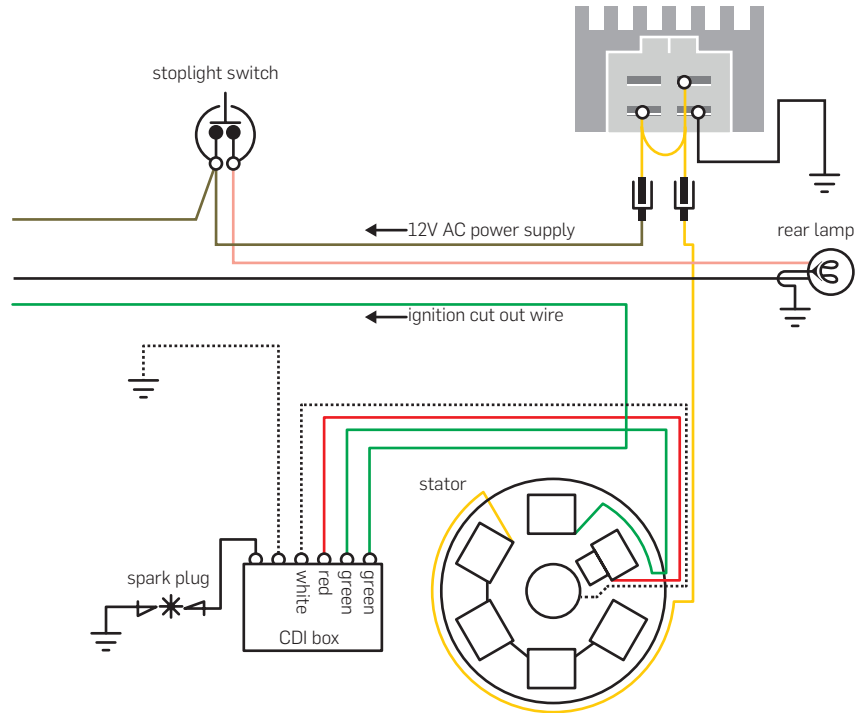

for reference: Sticky page 281

LAMBRETTA

ORIGINAL TYPE AC LOOM, 12 V ELECTRONIC IGNITION

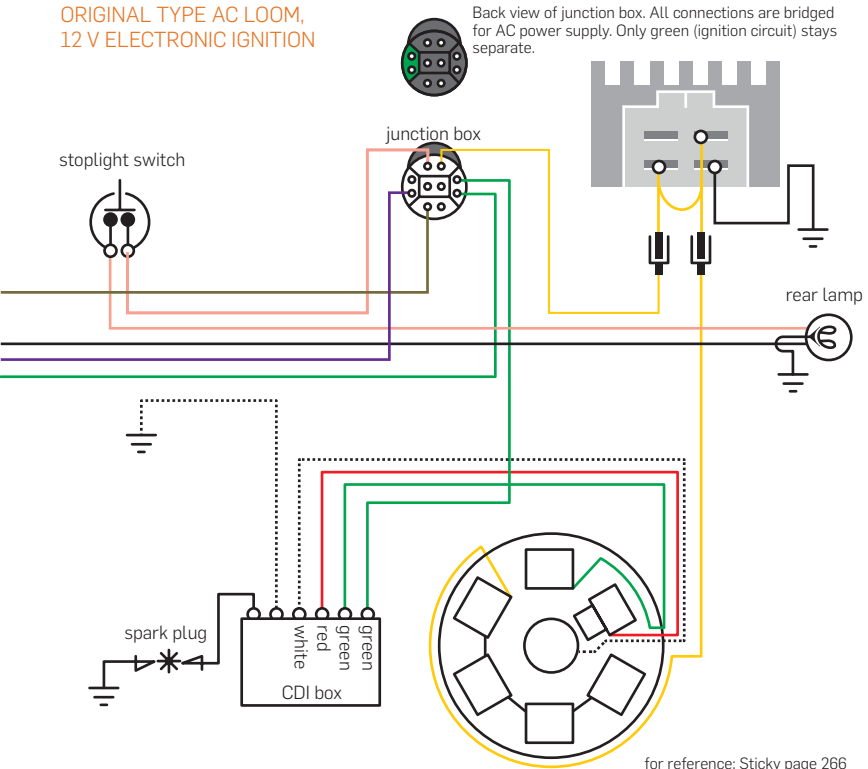

for reference: Sticky page 266

LAMBRETTA

ORIGINAL TYPE DC LOOM, 12 V ELECTRONIC IGNITION

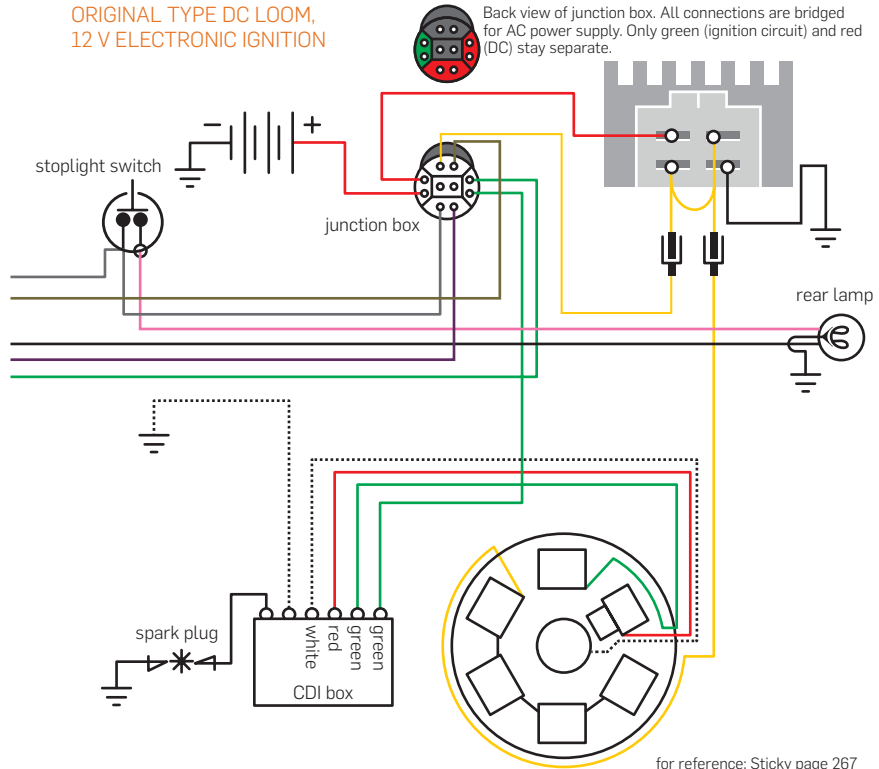

for reference: Sticky page 267

LAMBRETTA

VARITRONIC/CASA LAMBRETTA

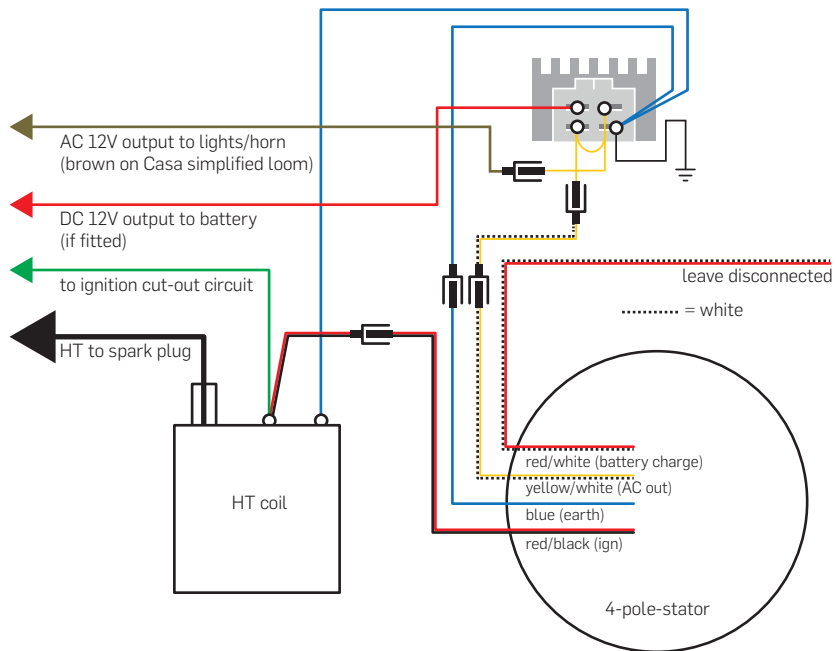

LAMBRETTA

VESPATRONIC/PARMAKIT

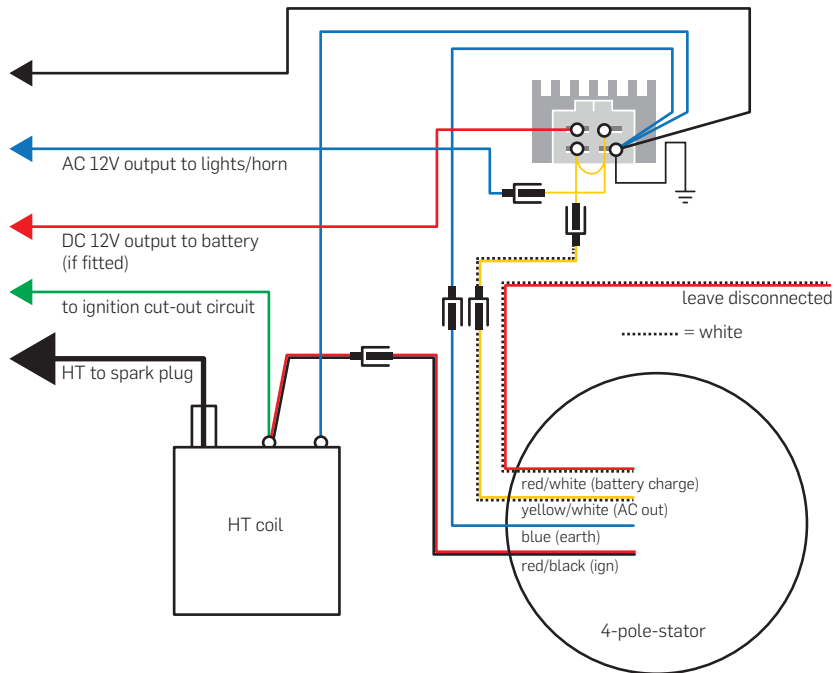

VESPA

VESPA 3-PIN REGULATOR

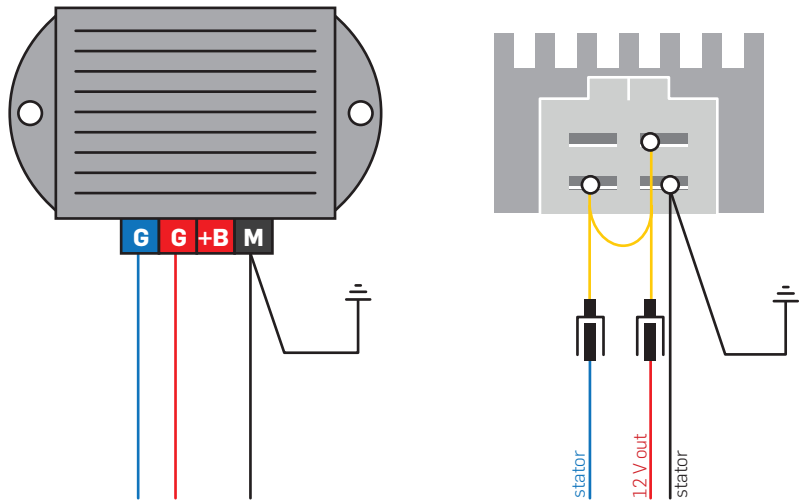

VESPA

VESPA 5-PIN REGULATOR

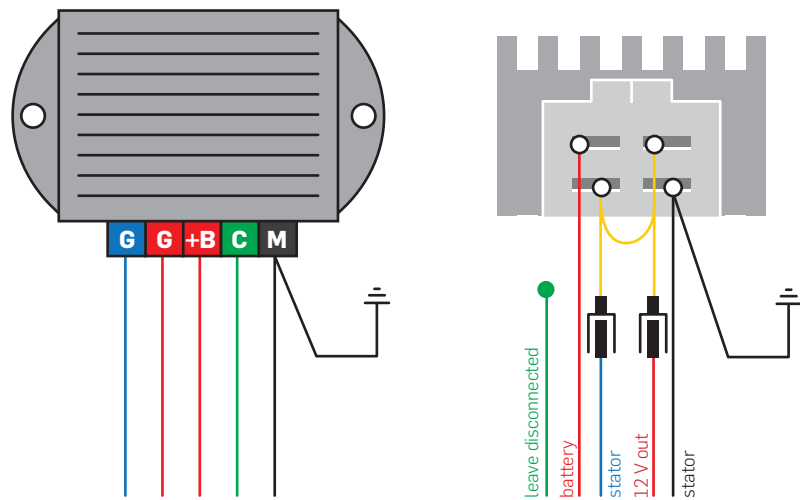

FIND ALL THE STUFF AT

WWW.BGM-TUNING.COM

The bgm PRO Vespa PX 200 BIG BOX gives a standard look with full expansion chamber performance.



The bgm PRO Lambretta BIG BOX for full expansion chamber performance with original look.

FIND ALL THE STUFF AT

WWW.BGM-TUNING.COM

The bgm PRO shockers for Vespa are fully adjustable, most versatile suspension units from race to rally going to daily commuting. With German TÜV certificate of conformity.

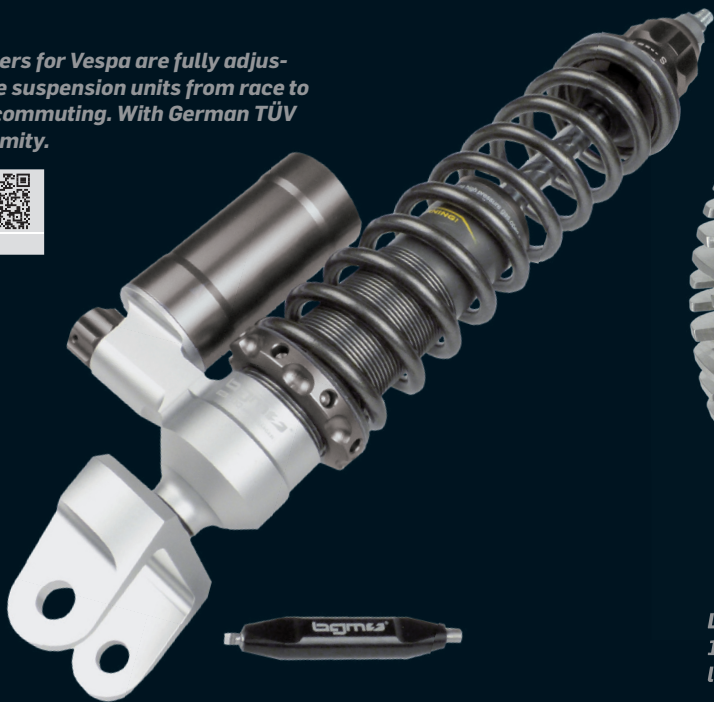

*Lambretta bgm PRO MRB RaceTour cylinder kits.
195 cc kits for small casings and 225 cc kits for
large casings.*

FIND ALL THE STUFF AT
WWW.BGM-TUNING.COM

*Lambretta bgm PRO flywheel
Made In Germany*



*Lambretta bgm PRO V3.0 stator
plate. Also available Lambretta
DC and electronic stator plates
for most Vespas.*

Scooter Center GmbH
Kurt-Schumacher-Str. 1
50129 Bergheim-Glessen
Germany

Fon +49 (0) 2238 - 3074 59
Fax +49 (0) 2238 - 3074 74
info@scooter-center.com
www.scooter-center.com

bgm[®]
MAIN DISTRIBUTORS

NORTHERN AMERICA:

jet★200
PERFORMANCE[®]

ITALY:

asa lambretta

FININI
lambretta
CENTRE

JAPAN:



UNITED KINGDOM:



SPAIN:



MAINLAND EUROPE:

SCOOTER CENTER

bgm  [®]

www.bgm-tuning.com